

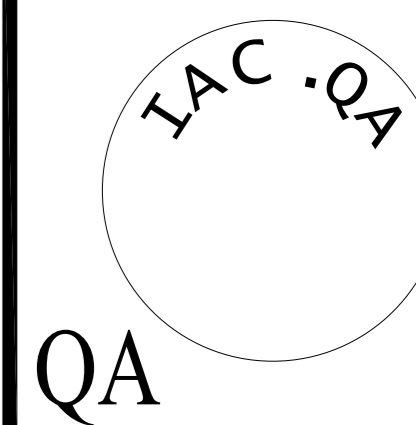

**INDUSTRIAL ACOUSTICS COMPANY LTD**

IAC House, Moorside Road, Winchester, Hampshire. SO23 7US.  
Telephone: +44 (0) 1962 873000. Facsimile: + 44 (0) 1962 873133. Telex: 47117.

TITLE: STC-59 ACOUSTIC WINDOW DETAILS  
PROJECT: STANDARDS  
CLIENT: .



COPYRIGHT © 2005 INDUSTRIAL ACOUSTICS COMPANY LTD.  
 THIS DESIGN AND DRAWING IS THE EXCLUSIVE PROPERTY OF THE INDUSTRIAL ACOUSTICS COMPANY LIMITED  
 AND IS SUBMITTED AS CONFIDENTIAL INFORMATION IN CONNECTION WITH YOUR ENQUIRY AND MUST NOT BE  
 USED FOR ANY OTHER PURPOSES. IT MUST NEITHER BE COPIED NOR LOANED WITHOUT WRITTEN PERMISSION.  
 UPON REQUEST IT MUST BE RETURNED IMMEDIATELY.

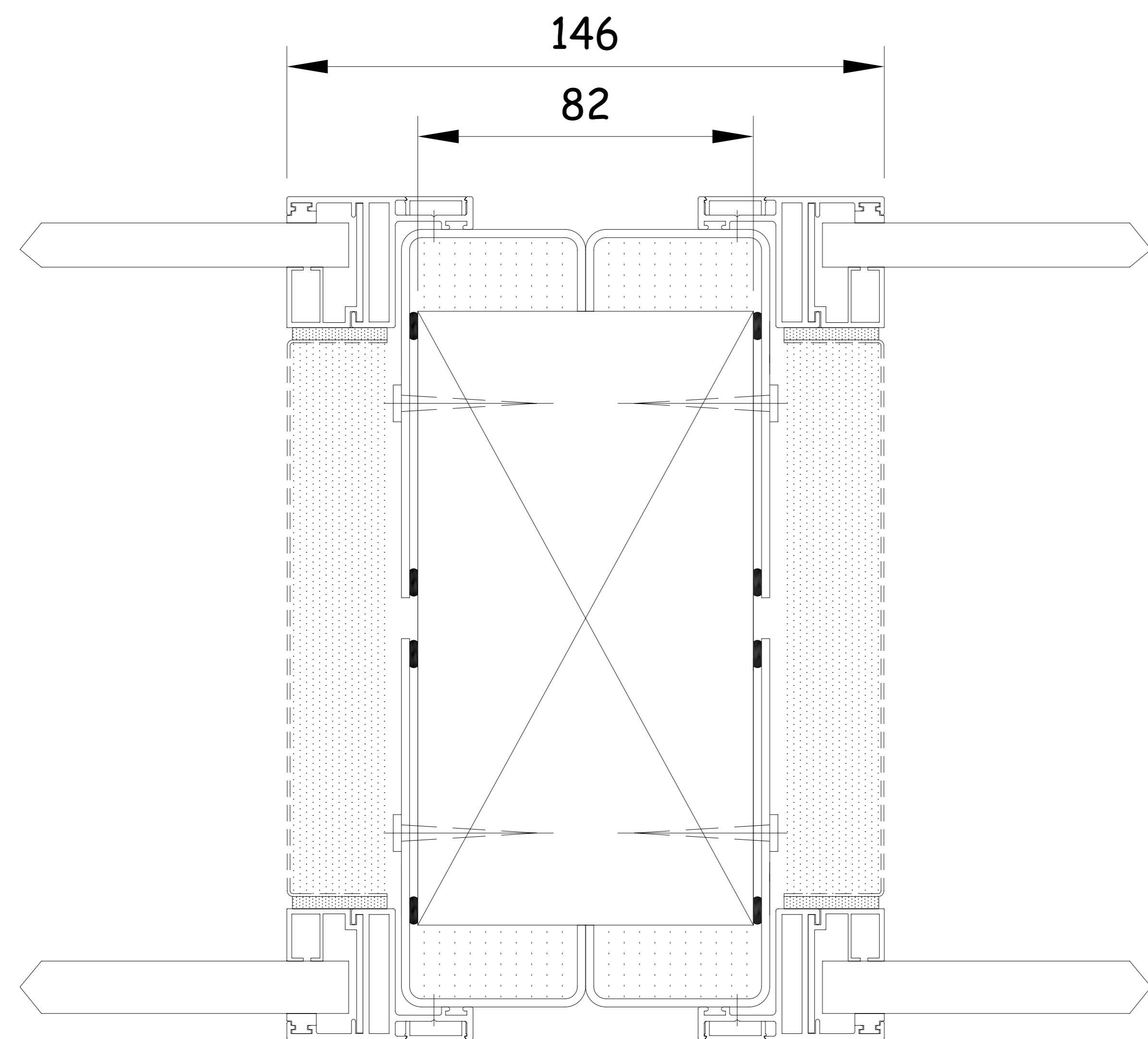

**VERTICAL MULLION DETAIL**

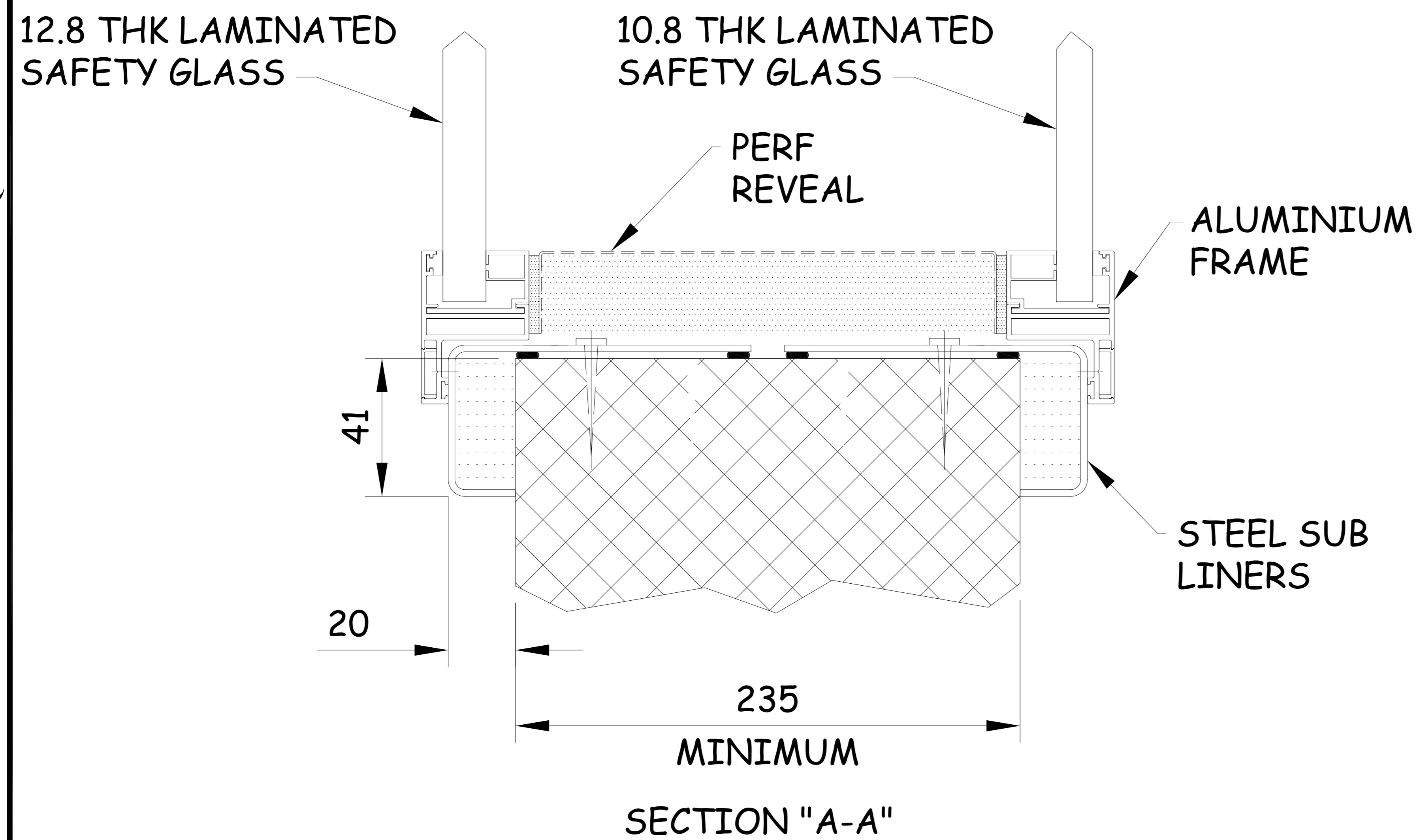
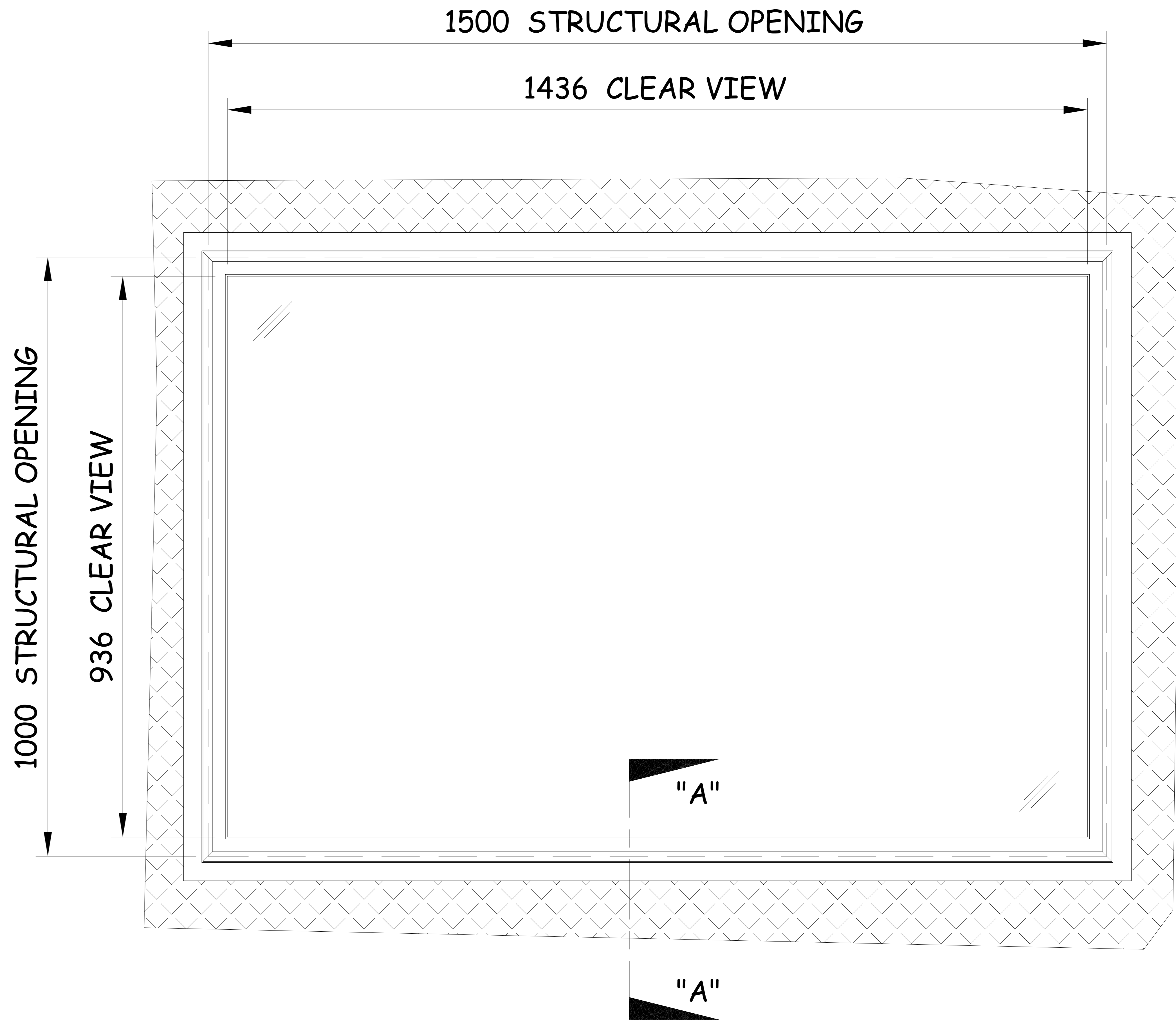

**SECTION "A-A"**

**FINISH: THE SUB LINERS & PERF REVEALS  
POLYESTER POWDER COATED RAL/BS COLOUR &  
GLOSS LEVEL E.G.MATT, SATIN OR FULL GLOSS  
TO BE ADVISED, THE ALUMINIUM FRAME SUPPLIED  
SELF COLOURED**

**FOR  
MANUFACTURE**  
 02.04.09

TOLERANCES UNLESS OTHERWISE STATED:  
UP TO 300 %%P(1.0) 3001 TO 6000 %%P(4.0)  
301 TO 1500 %%P(2.0) OVER 6000 %%P(6.0)  
1501 TO 3000 %%P(3.0)

(A) WELDING TO CONFORM TO BS.1140 OR BS.EN 1011-2 & BS.EN ISO 5817  
(B) CONSUMABLES TO CONFORM TO BS EN 499, AND BS EN 440.  
(C) WELDING SYMBOLS ARE IN ACCORDANCE WITH BS.EN 22553 & BS.EN ISO 2553

REF	A	17.12.08	A.F.		
CHANGE No:	ISS	DATE	CHKD	APPR	Q.A.

DRN BY:  
**SF**  
DATE:  
17.12.08

CHK'D BY:  
**A.F.**  
DATE:  
02.04.09

APPD BY:  
DATE:

DWG No:  
**A3- SD-W7**  
PROJECT No.  
Standards

SHEET OF  
1 1  
SCALE  
NTS

ISSUE  
**A**